

SELF LEARNING MODULE INSTALLATION INSTRUCTIONS

For Harley-Davidson® Softail, Touring, Dyna, Sportster and V-Rod models

READ ALL THE DIRECTIONS CAREFULLY BEFORE STARTING THIS INSTALLATION. DO NOT APPLY FORCE WHEN INSTALLING THE SENSOR CONNECTORS TO THE SENSORS. THIS WILL RESULT IN BENDING THE ALIGNMENT OF THE TERMINAL PINS, LOCATED IN THE CONNECTORS AND SENSORS. USE THE MODEL SPECIFIC DIAGRAMS TO DETERMINE WIRE FUNCTION. IT MAY BE NECESSARY TO REFER TO A FACTORY SERVICE MANUAL TO PROPERLY LOCATE THE APPROPRIATE SENSORS TO COMPLETE THIS INSTALLATION.

STEP 1 - BATTERY CONNECTION

Locate the battery and disconnect the negative battery cable. Mount the module in the open area in front of the battery with 2-tie straps or velcro straps, directing the harness from the module towards the 6 o'clock position.

STEP 2 - THROTTLE POSITION SENSOR (TPS):

Remove the air cleaner assembly and unplug the TPS sensor connector at the TPS sensor. The harness includes (2) TPS connectors which should be routed under the gas tank into the factory wire loom to the TPS sensor. The TPS sensor is located on the left side of the throttle body. Plug the (2) TPS connectors from the module in between the TPS sensor and to the factory TPS connector.

STEP 3 - CRANK POSITION SENSOR (CPS) TWO GREY CONNECTORS:

Unplug the Crank Position Sensor factory connector at the sensor. This sensor is located at the lower front crank case. Route the module's (2) Gray CPS connectors underneath the bottom of the motorcycles frame, along with the main harness loom. Plug the (2) CPS connectors from the module in between the CPS sensor and to the factory CPS connector.

STEP 4 - O2 SENSOR:

Systems equipped with factory O2 sensors

Rear: Unplug the Rear O2 sensor connector from the factory harness, which is located at the Rear exhaust pipe. Route the module's harness which includes (2) O2 sensor connectors and connect one connector to the Rear O2 sensor and connect the other connector to the main factory O2 sensor connector.

Front: Unplug the Front O2 sensor connector from the factory harness, which is located at the Front exhaust pipe. Route the module's harness which includes (2) O2 sensor connectors, and connect one connector to the Front O2 sensor and connect the other connector to the main factory O2 sensor connector.

Systems not equipped with factory O2 sensors

NOTE: Many aftermarket exhaust systems are now equipped with plugged O2 sensor bungs which can be removed to accept an aftermarket O2 sensor. Typically these bungs already have a thread size of 18 mm x 1.5 mm. Exhaust systems not equipped with O2 sensor bungs need to have the supplied 18 mm x 1.5 mm thread size bung welded to the exhaust pipe in order to install an O2 sensor.

The O2 sensor bung should be installed 3 to 6 inches away from the rear cylinder exhaust port and in front of the exhaust torque tube pipe area. The module prefers to receive information from the O2 sensor from an area that is NOT contaminated from atmospheric air.

This air may enter through the tail pipe of an unrestricted or un-baffled exhaust pipe. The bung should not be installed in the "5 to 7 o'clock" area. If mounted in this area the O2 sensor can be damaged. The moisture from the gases exiting from the rear cylinder exhaust port will harm the ceramic shell element of the O2 sensor.

Make sure to clean the threads of the bung with an 18 mm x 1.5 mm tap after welding the bung to the exhaust pipe. Route the module's harness which includes an O2 sensor to the sensors bung location and install the sensor. Carefully torque the O2 sensor nut to allow the crush washer to "flatten," this allows the washer to seal the O2 sensor to the bungs surface.

STEP 5 - POWER SOURCE:

The power source should only be a key-on fused +12 volt ignition source.

There are a variety of key-on switched power sources for different model years. We provide a few recommended location points to obtain power sources from:

1995 to 2001 (Magneti-Marelli ECU)

For these models there are limited options to connect the power. Our recommendation is the switched power source located at pin #26, which is a white wire. It will be necessary to remove the ECU from its mounting bracket by simply loosening the mounting screw. This will allow you to slide back the pin protection cover and access the identification numbering of the correct pin location. Use the supplied T-Tap and blade-terminal to connect the red wire from the module to the white wire which is pin # 26 switched key-on + 12 volts.

2001 to 2009 (Delphi ECU, except Throttle by Wire)

The switched power source located at pin # 13, which is a white/black wire. The ECU can be removed from its mounting bracket. By opening the two half sections of the pin protection cover, you will now be able to access the identification numbering to determine the correct pin location. With the supplied T-Tap and Blade-Terminal connect the red wire from the module to the white/black wire pin # 13 switched +12 volts.

2008-2009 Touring (Throttle by Wire)

The switched power source is located at pin # 72, which is also a white/black wire.

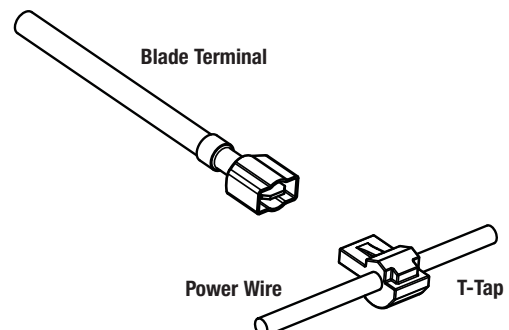

Using Factory Data-Link Connector Power Source

2001 to 2007 Delphi ECU has a switched power source located at the Data-Link Connector (pin #4) which is a switched key-on + 12 volts. The wire color for 2001 to 2003 Delphi ECU is white/black and for 2004 to 2007 Delphi ECU is grey in color. With the supplied T-Tap and Blade-Terminal connect the red wire from the module to the white/black or grey wire which is pin # 4 switched key-on + 12 volts at the Data-Link connector.

NOTE: Connections should be made by soldering and heat shrinking the connection.

STEP 6 - GROUND SOURCE:

Use the eyelet connector on the module's black wire and fasten it to the negative ground stud or to the negative battery post bolt. Reconnect the negative battery cable to complete the installation.

FUNCTIONS AND OPERATIONS OF THE MODULE

The LED is located at the top left side of the front of the module. With the module installed correctly and the harness exiting the unit from the 6 o'clock position you will see an LED displayed with the key-on.

The LED will blink from a Red to Green with the key-on only. The LED will blink Green after 90 seconds of engine operation and will be in close-loop mode.

START-UP DIAGNOSTIC SYSTEM-CHECK MODE

The system is checked every time the key-on power source is turned on. The factory "FI-Light" will display on the indicator panel, blink-on then-off and then blink-on again before staying off. This is a function test the module performs on start-up to indicate that the system is installed correctly.

NOTE: The controller is not legal for use or installation on motor vehicles operated on public highways in the State of California or any other State where similar emission control laws may apply. The user shall determine suitability of the products use. The user shall assume all risk and liability in violation of regulations and any financial obligations due to vehicle inspections or emissions tests.

Limited Camshaft Modifications

The SLM module will facilitate for the installation of, exhaust systems, air cleaners/intake systems, including limited camshaft modifications. The camshafts are limited to "most bolt in camshafts", where the installation does not exceed the maximum lift listed below:

- 0.520" lift for a 88ci to 103ci motors
- 0.580" lift for 96ci to 110ci motors, w/no changes to the factory valve or rocker arm configurations

The SLM module may support limited camshaft installations, when no other changes are made to the motor, this would apply to an 88ci to a 110ci camshaft upgrade only. When installing camshafts over 0.600" of lift which also includes additional engine modifications, there would be a need to have the engine tune with an after market tuner. After the motor has been tuned in to accept the new camshafts and additional engine modifications, the SLM module may be installed to fine/tune the closed/loop system.

#SLM01

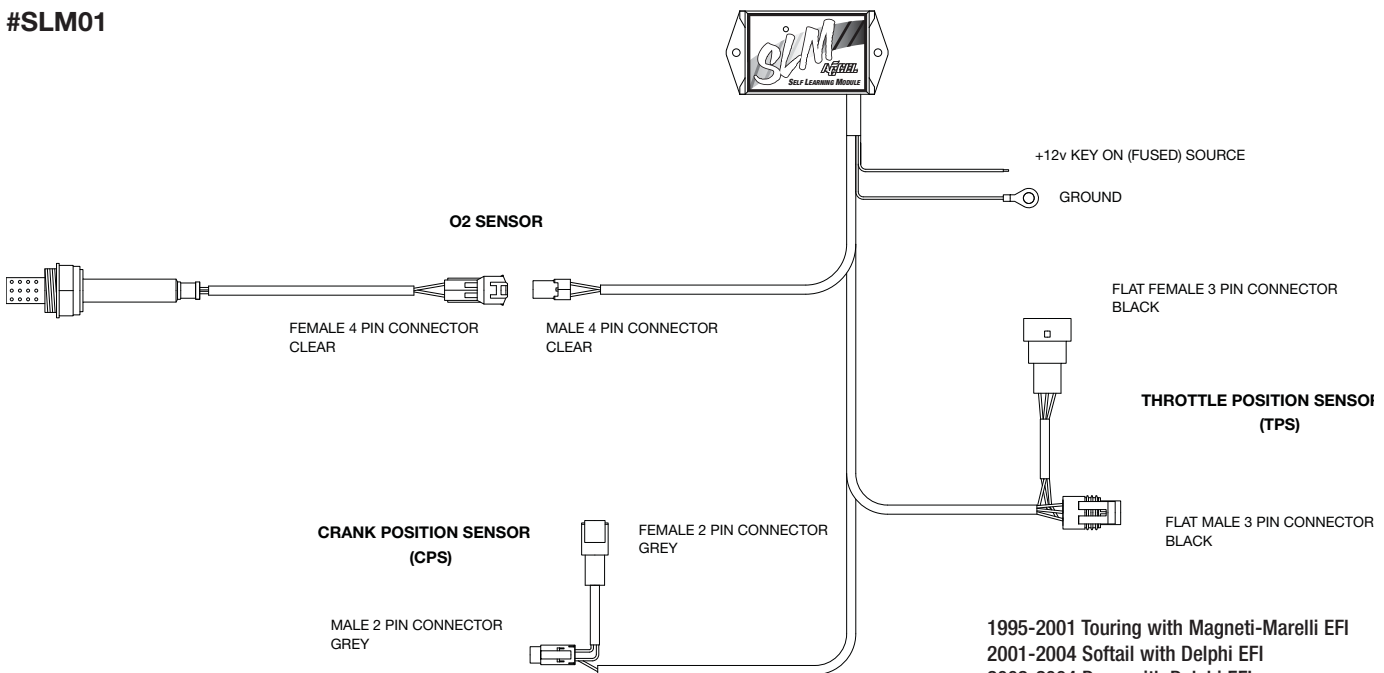

1995-2001 Touring with Magneti-Marelli EFI
2001-2004 Softail with Delphi EFI
2002-2004 Dyna with Delphi EFI
2002-2004 Touring with Delphi EFI
2002-2007 V-Rod with Delphi EFI
2005 Softail, Dyna and Touring with Delphi EFI
and Flat "Throttle Position Sensor" plug

NOTE: This kit comes complete with one (1) O2 Sensor and one (1) weld in bung.

#SLM02

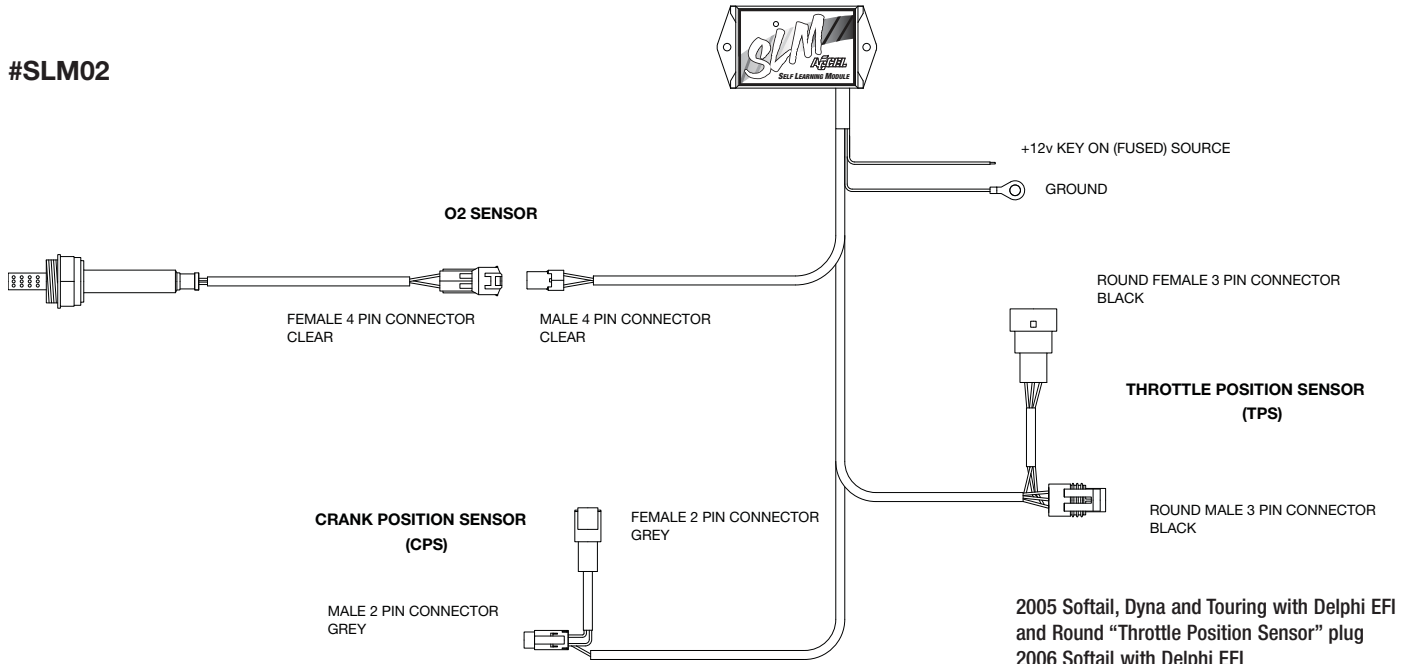

2005 Softail, Dyna and Touring with Delphi EFI and Round "Throttle Position Sensor" plug
 2006 Softail with Delphi EFI
 2006 Touring with Delphi EF

NOTE: This kit comes complete with one (1) O2 Sensor and one (1) weld in bung.

#SLM03

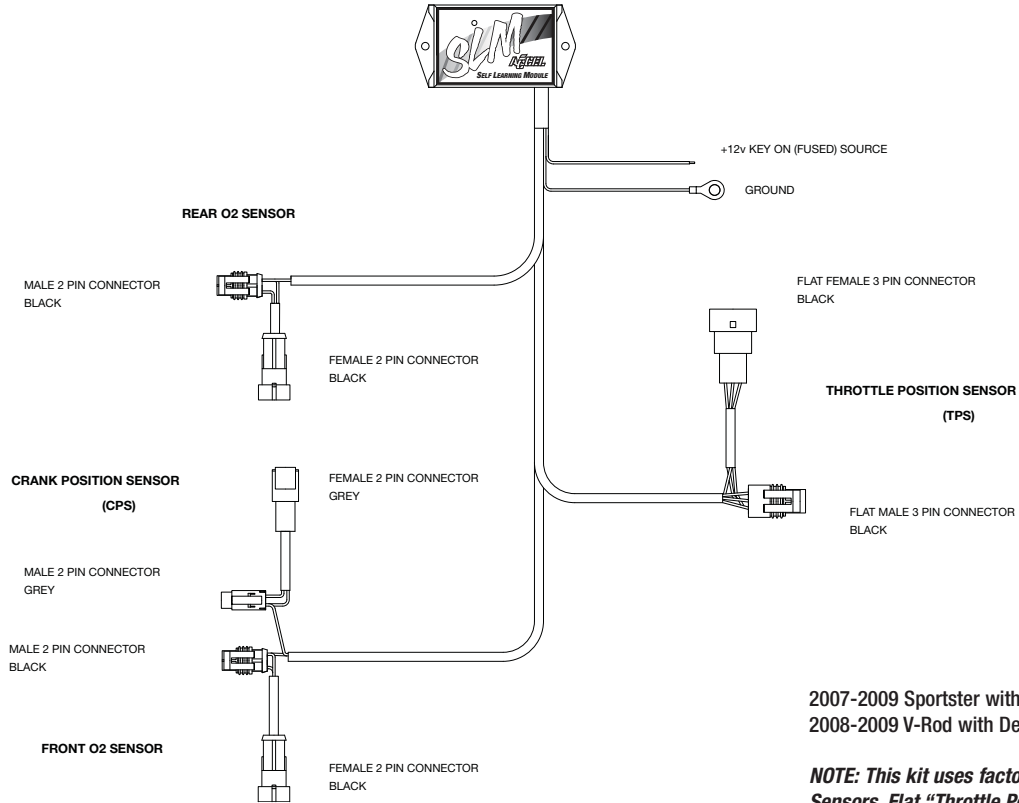

2007-2009 Sportster with Delphi EFI
 2008-2009 V-Rod with Delphi EFI

NOTE: This kit uses factory installed O2 Sensors. Flat "Throttle Position Sensor" Plug

#SLM04

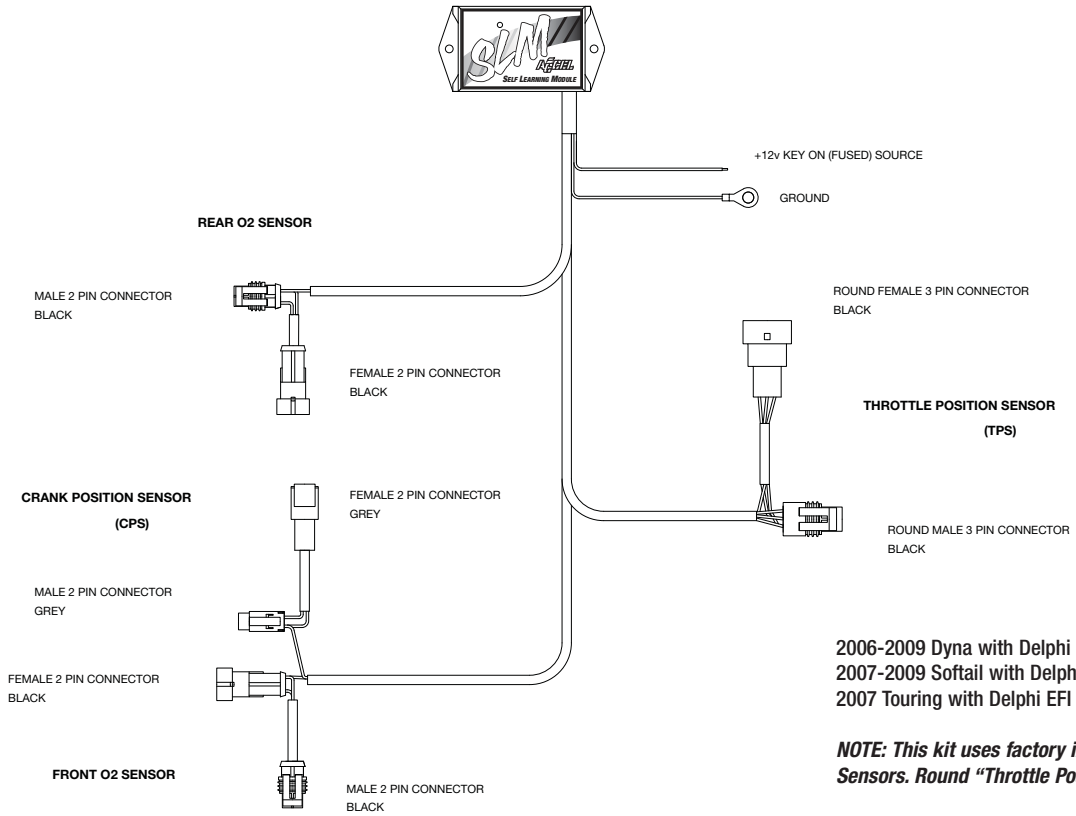

#SLM05

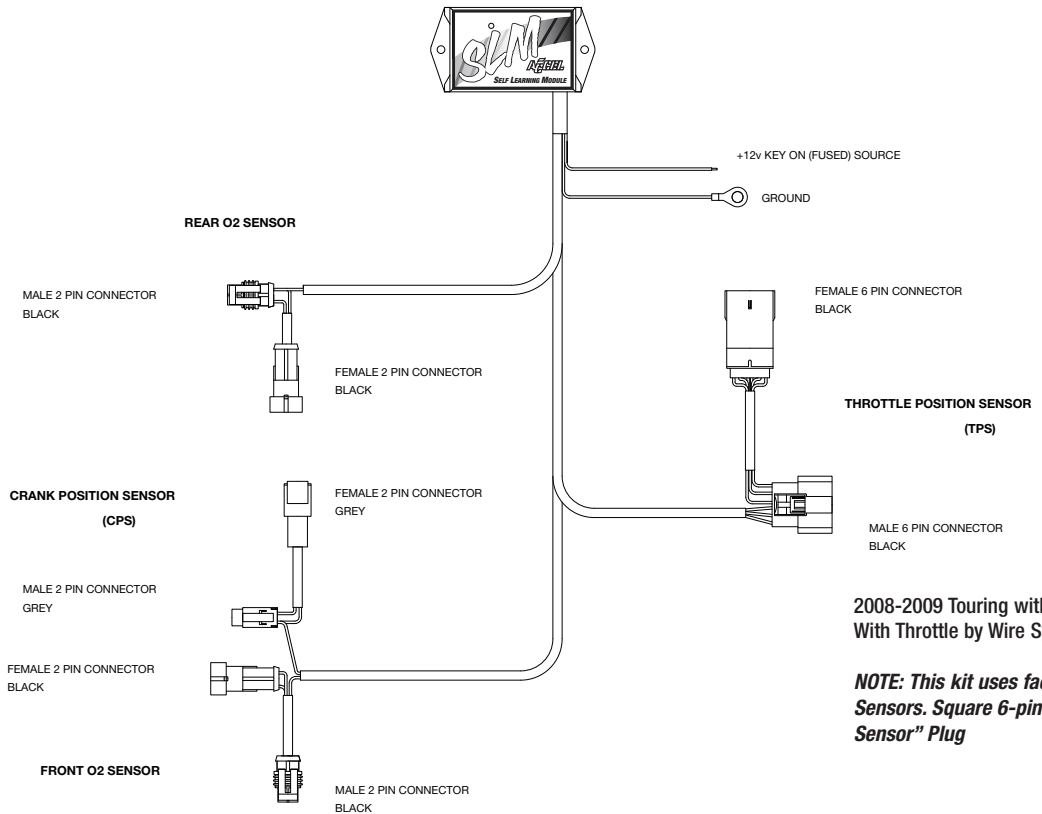

ACCEL MOTORCYCLE IS A DIVISION OF PRESTOLITE PERFORMANCE
10601 MEMPHIS AVE #12, CLEVELAND, OH 44144
216.688.8300 FAX 216.688.8306

FORM SLMINST
(Rev. A) 09/09
Made in U.S.A.
Printed in U.S.A.